

# Cattaneo

new lighting atmospheres

## HERON

810/120M

810/95M

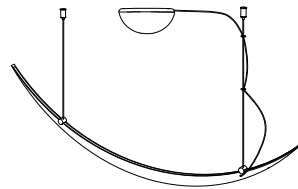

220 - 240 V  
24 V Dc CL. I



LA SORGENTE LUMINOSA DI QUESTO APPARECCHIO DEVE ESSERE SOSTITUITA ESCLUSIVAMENTE DAL PRODUTTORE O DAL SUO SERVIZIO ASSISTENZA O DA PERSONALE QUALIFICATO EQUIVALENTE

THE LIGHT SOURCE CONTAINED IN THIS LUMINAIRE SHALL ONLY BE REPLACED BY THE MANUFACTURER OR A SIMILAR QUALIFIED PERSON

SE IL CAVO FLESSIBILE ESTERNO DI QUESTO APPARECCHIO VIENE DANNEGGIATO DEVE ESSERE SOSTITUITO DAL COSTRUTTORE O DAL SUO SERVIZIO ASSISTENZA O DA PERSONALE QUALIFICATO EQUIVALENTE AL FINE DI EVITARE PERICOLI

IF THE EXTERNAL FLEXIBLE CABLE OF THIS LUMINAIRE IS DAMAGED, IT SHALL BE EXCLUSIVELY REPLACED BY THE MANUFACTURER OR HIS SERVICE AGENT OR A SIMILAR QUALIFIED PERSON IN ORDER TO AVOID HAZARDS

### 1

### 2 ANCORAGGIO A SOFFITTO CEILING ANCHORAGE

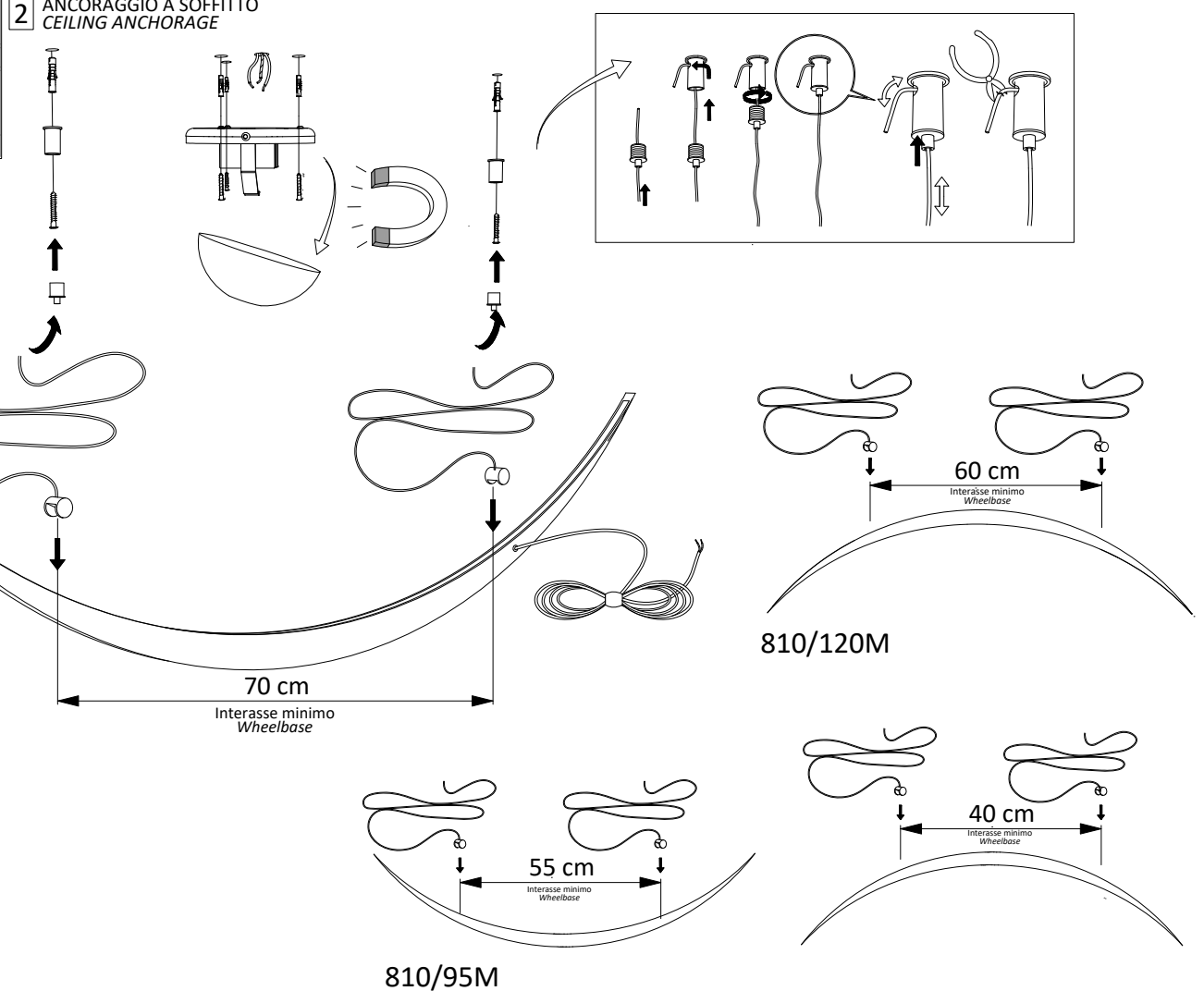
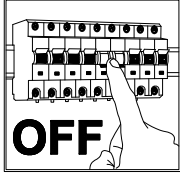

### 3 INSTALLAZIONE INSTALLATION

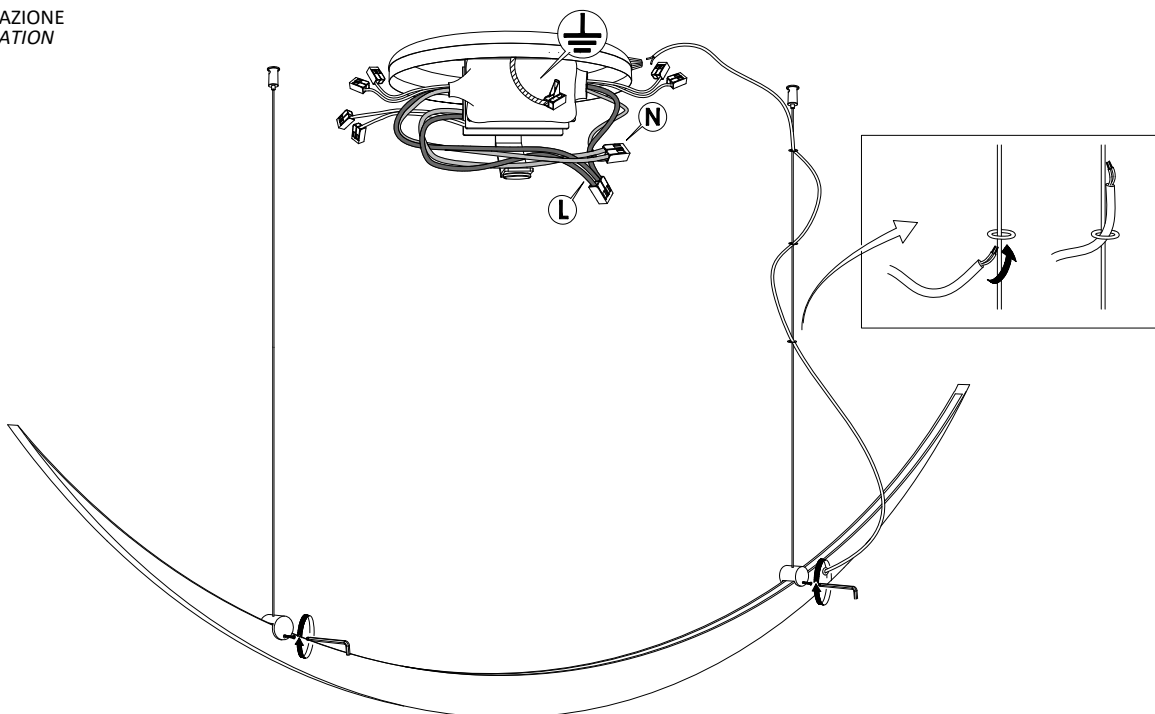

# Cattaneo

new lighting atmospheres

## HERON

810/120M

810/95M

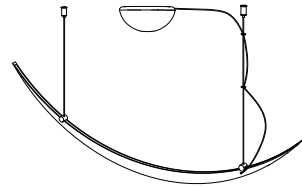

220 - 240 V  
24 V Dc CL. I



LA SORGENTE LUMINOSA DI QUESTO APPARECCHIO DEVE ESSERE SOSTITUITA ESCLUSIVAMENTE DAL PRODUTTORE O DAL SUO SERVIZIO ASSISTENZA O DA PERSONALE QUALIFICATO EQUIVALENTE

THE LIGHT SOURCE CONTAINED IN THIS LUMINAIRE SHALL ONLY BE REPLACED BY THE MANUFACTURER OR A SIMILAR QUALIFIED PERSON

SE IL CAVO FLESSIBILE ESTERNO DI QUESTO APPARECCHIO VIENE DANNEGGIATO DEVE ESSERE SOSTITUITO DAL COSTRUTTORE O DAL SUO SERVIZIO ASSISTENZA O DA PERSONALE QUALIFICATO EQUIVALENTE AL FINE DI EVITARE PERICOLI

IF THE EXTERNAL FLEXIBLE CABLE OF THIS LUMINAIRE IS DAMAGED, IT SHALL BE EXCLUSIVELY REPLACED BY THE MANUFACTURER OR HIS SERVICE AGENT OR A SIMILAR QUALIFIED PERSON IN ORDER TO AVOID HAZARDS

### 6 CHIUSURA ROSONE LAMP CAP CLOSURE

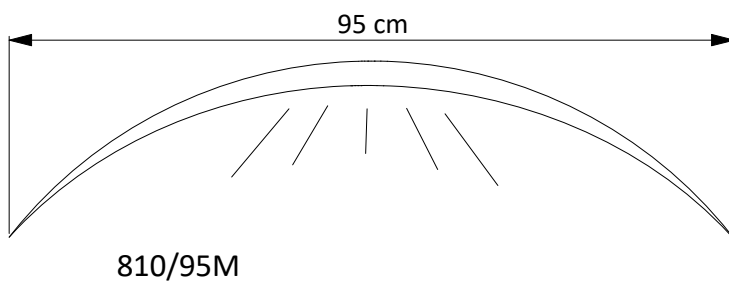
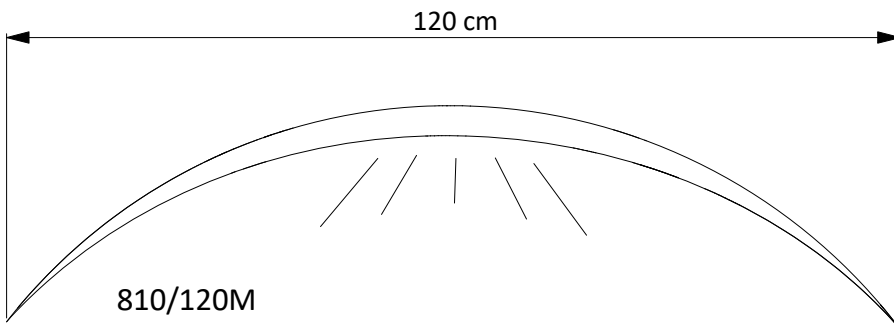
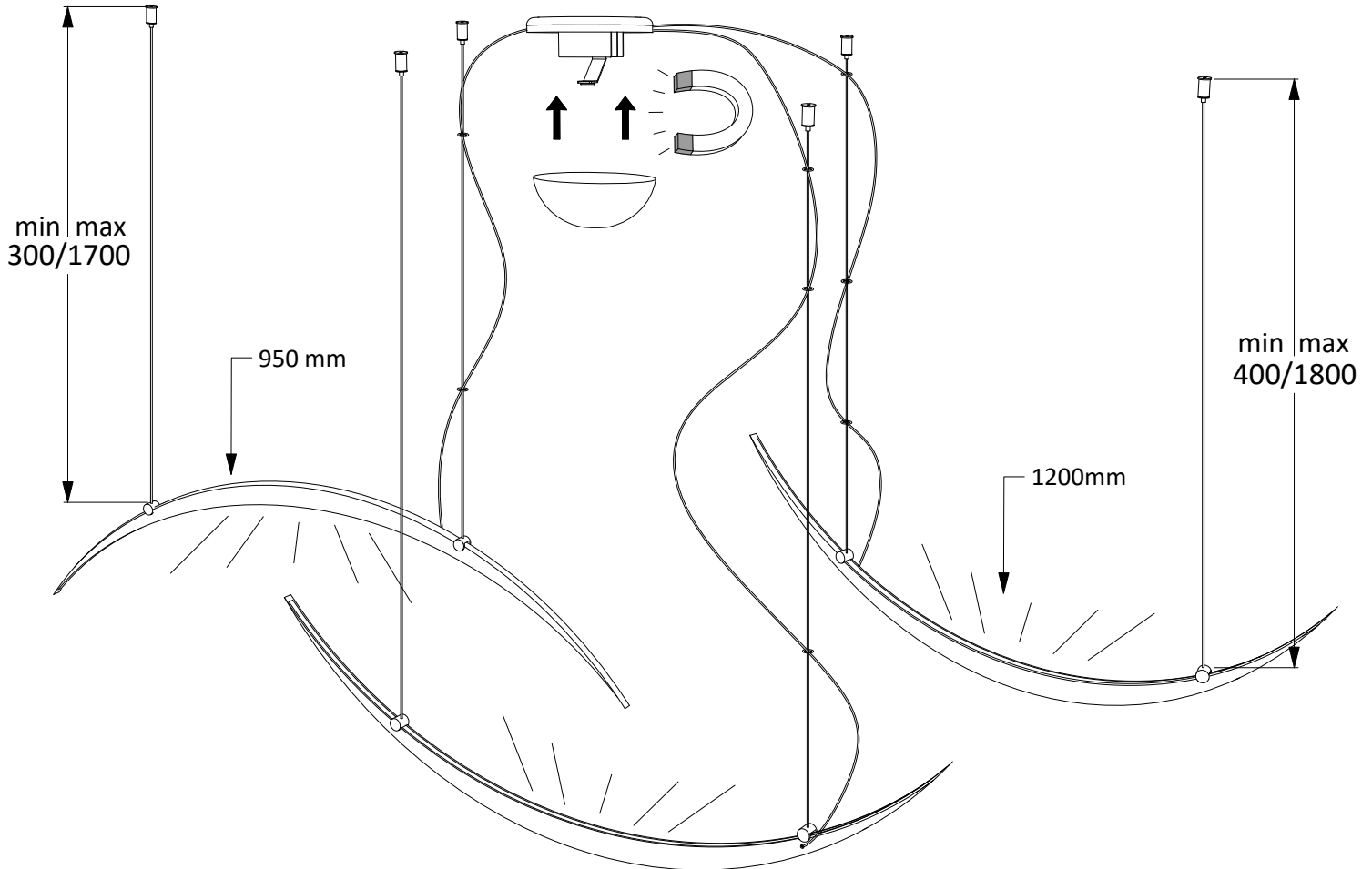

# Cattaneo

new lighting atmospheres

## HERON

810/120M  
810/95M

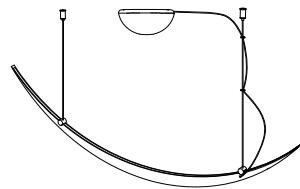

220 - 240 V  
24 V Dc CL. I



LA SORGENTE LUMINOSA DI QUESTO APPARECCHIO DEVE ESSERE SOSTITUITA ESCLUSIVAMENTE DAL PRODUTTORE O DAL SUO SERVIZIO ASSISTENZA O DA PERSONALE QUALIFICATO EQUIVALENTE

THE LIGHT SOURCE CONTAINED IN THIS LUMINAIRE SHALL ONLY BE REPLACED BY THE MANUFACTURER OR A SIMILAR QUALIFIED PERSON

SE IL CAVO FLESSIBILE ESTERNO DI QUESTO APPARECCHIO VIENE DANNEGGIATO DEVE ESSERE SOSTITUITO DAL COSTRUTTORE O DAL SUO SERVIZIO ASSISTENZA O DA PERSONALE QUALIFICATO EQUIVALENTE AL FINE DI EVITARE PERICOLI

IF THE EXTERNAL FLEXIBLE CABLE OF THIS LUMINAIRE IS DAMAGED, IT SHALL BE EXCLUSIVELY REPLACED BY THE MANUFACTURER OR HIS SERVICE AGENT OR A SIMILAR QUALIFIED PERSON IN ORDER TO AVOID HAZARDS

### 4 CONNESSIONE ELETTRICA ELECTRICAL CONNECTION

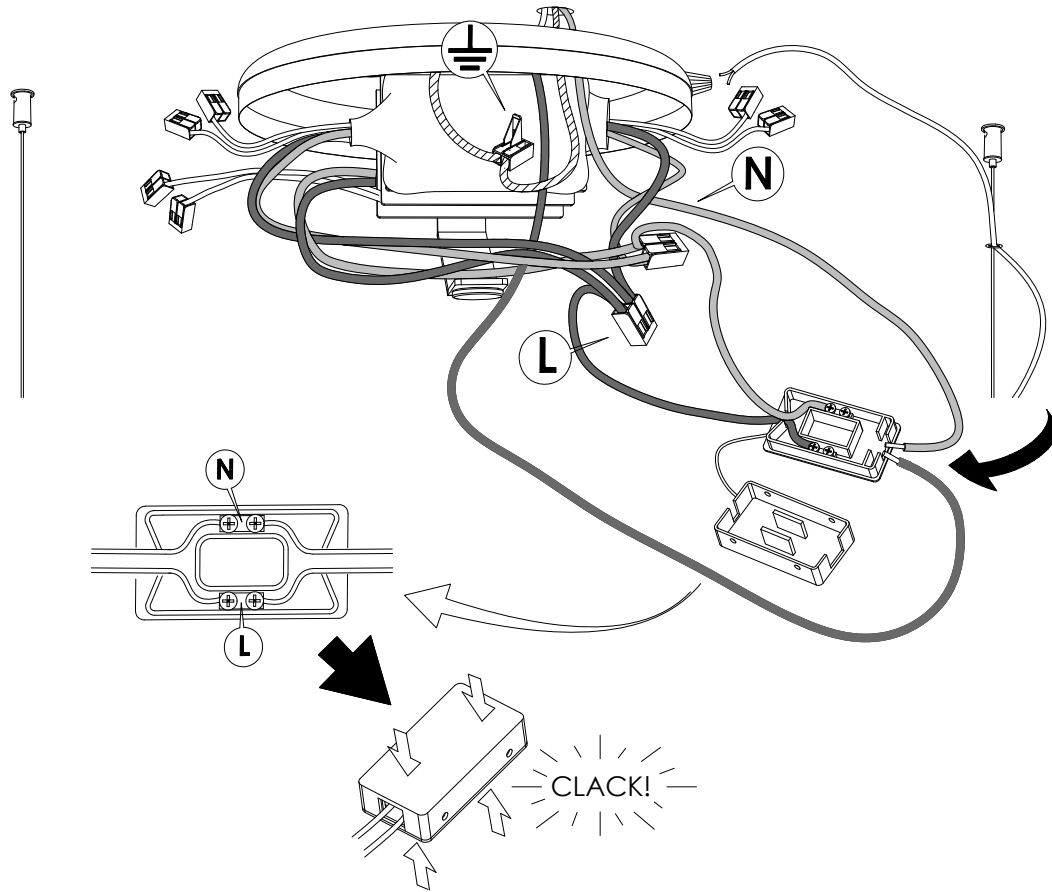

### 5 CONNESSIONE TRA PARTI CONNECTION BETWEEN APPLIANCES

